



User Guide

Trimble Access™ Mines

Version 2026.10

Revision A

June 2026

Contents

Trimble Mines software	3
Adding data to the job	4
To auto stake a centerline	5
To auto stake a gradeline	8
To auto stake laser lines	11
To auto stake laser lines from a centerline	13
To auto stake blast holes	15
To auto stake pivot points	17
To project a line	19
To auto stake wall lasers	21
Auto stake settings	22
Legal notices	24

Trimble Mines software

Trimble® Mines software is specifically designed for surveying in mining environments.

Use Mines to:

- Define and auto stake center, grade, and laser lines to align a drilling rig.
- Auto stake predefined blast hole positions.
- Auto stake predefined pivot points to position a drilling rig.
- Generate reports for the surveyed mine.

To use Mines, you must switch to the Mines app. To switch between applications, tap ☰ and tap the name of the app you are currently using, and then select the application to switch to.

TIP - The Mines app includes the full **Cogo** menu from General Survey so that you can carry out coordinate geometry (cogo) functions without having to switch to General Survey. You can also access some of these cogo functions from the tap and hold menu in the map. For information on all available cogo functions, refer to the *Trimble Access General Survey User Guide*.

When starting a survey you are prompted to select the survey style you have configured for your equipment. To learn more about survey styles and related connection settings refer to the appropriate topics in the *Trimble Access Help*.

To switch between applications, tap ☰ and tap the name of the app you are currently using, and then select the application to switch to.

To automatically stake out...	Select...
A line at set intervals along the mine back (ceiling).	Centerline
A line at set intervals along the mine walls.	Grade line
Intersection points between the mine walls and a line defined by two points.	Laser lines
Intersection points between the mine wall and laser lines defined at right angles relative to the centerline at a defined interval.	Laser lines offset from a centerline
The intersection point between a mine face and a line defined by two points.	Blast holes
Pivot points that have been projected up onto the mine back.	Pivot points
The intersection point between a mine face and a line.	Project line

To automatically stake out...	Select...
The optimal position of a wall laser mounted to the mine wall, which can be used as a reference to mark the working face.	Wall laser



TIP – To watch how to stake out different lines and points and how to configure options, take a look at the [Trimble Access Mines playlist](#) on the [Trimble Access YouTube channel](#).

Adding data to the job

You can add linework to the job from a DXF or STR (Surpac) file.

Points can be imported into the job, linked to the current job, or imported into another job and that job linked to the current job. To import points, tap  and select **Job** and then tap **Import**. Depending on the features you want to stake, the points in the job must meet the following criteria:

- Pivot points must be identified by either a prefix or suffix in their point name.
- Laser line points must be matched pairs of points defined using their point names. A point must have a prefix or suffix to identify it as the left or the right hand end of the line. The remainder of the point name must be identical for a match pair to be found. For example, if the Left points prefix is L and the Right points prefix is R, then the following points would be identified as matched pairs: L1–R1, L15–R15, L101–R101, etc.
- Blast hole points must be matched pairs of points defined using their point names. A point must have a prefix or suffix to identify it as the blast hole collar or toe. The remainder of the point name must be identical for a match pair to be found. For example, if the collar points suffix is C and the toe points suffix is T, then the following points would be identified as matched pairs: 1C–1T, 15C–15T, A1C–A1T, etc.

To auto stake a centerline

Automatically stake out centerlines along all surfaces of the mine. You can start and stop auto stakeout at any point in the stakeout workflow.

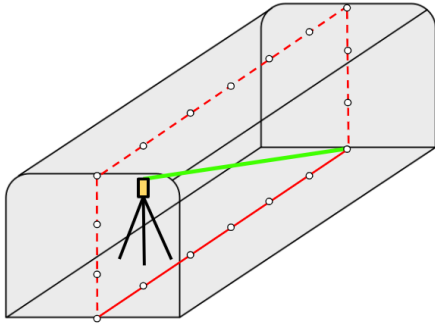

1. To define the centerline and auto stake sequence:
 - a. Start by doing one of the following:
 - In the map, select the line and then tap **Auto stake / Centerline**.
 - Tap **☰** and select **Auto stake / Centerline** and select the **Start point** and the **End point**.
When selecting points, select them from the map or tap **▶** for other selection methods.
 - b. Define an **Interval** for staking the line.
 - c. Select the **Start surface** from which to begin the auto stake routine and then define the **Sequence** in which the auto stake routine will stake each surface.
The **Start surface** options are: ceiling, front face, floor, or rear face. By default the stakeout will begin at the ceiling, and continue in the following order: front face, floor, rear face.
To reverse the sequence, tap the **Reverse** softkey. This setting is remembered if you repeat the stakeout of the line.
 - d. If required, define a **Horizontal offset**, which can be applied left or right of the centerline.
The offset is used to adjust the design positions.

The **Line definition** information box shows the length, azimuth, and grade of the created line.

TIP – In both the map and camera views, the defined centerline appears as a black dashed line. A yellow arrow highlights the active surface and indicates the staking direction.

2. Tap **Next**.
3. Tap the **Options** softkey to enter values for the **Point details**, **Position tolerance**, and **Settings** or accept the default values. See [Auto stake settings, page 22](#). Tap **Next**.

NOTE – Position tolerance values refer to the tolerance when searching for the next position on the mine surface. Position tolerance in this context does not refer to the precision or accuracy of the measured point.

Before the auto stake routine can start, you must measure the existing mine surfaces as well as the defined start point. This allows the software to accurately project the design centerline onto each mine face and determine the intersection points for marking. Measuring to the start point helps with efficiency and avoids rework.

4. Measure the mine faces and the auto stake start position:

NOTE – Measuring close to the center of the mine surface will provide the best results.

- a. Aim to the front face and tap **Measure**.
- b. Aim to the floor and tap **Measure**.
- c. Aim to the ceiling and tap **Measure**.
- d. Aim to the rear face and tap **Measure**.

To remove the rear face from the measurement workflow, tap the **Skip** softkey when prompted to measure the rear face.

- e. Aim to the start point and tap **Measure**. To start the auto-stakeout from the start point of the defined centerline, tap **Skip**.

The auto stake routine automatically begins after you have measured to the mine surfaces and the autostake start position.

- If you measured an auto stake start point, the auto stakeout begins at that point and proceeds in the sequence you defined in step 1.
- If you skipped measuring the start position, the auto stakeout proceeds from the start of the defined centerline and proceeds in the default stakeout order.

During auto stakeout:

- When a position is found within tolerance, the **Mark point** event sounds and:
 - If the instrument has a tracklight, the laser pointer **and** the tracklight **flash** for the period defined in the **Mark delay** field.
 - If the instrument is a Trimble SX12 scanning total station, the instrument changes to **STD** mode and the laser pointer **stops flashing** and moves to position itself at the EDM location. The laser pointer **changes to solid** while the Target Illumination light (TIL) flashes for the period defined in the **Mark delay**

field. When the point is stored the instrument automatically returns to **TRK** mode and the laser pointer resumes flashing.

At the end of the **Mark delay** period the instrument auto stakes the next point. Use the **Prev** and **Next** softkeys to skip to the previous or next point.

- During the iteration process, the stakeout deltas are displayed, indicating the direction the instrument EDM needs to go to reach the target. A value shown in red indicates the deltas are out of tolerance. Tap **Pause** to temporarily halt the iteration. The software switches the instrument to tracking mode, allowing you to use the arrow keys on the controller or the video screen to move the instrument EDM closer to the target. Once the delta values are shown in black, tap **Store** to store the record, restart the auto stakeout sequence, and move to the mark point step.
- If a point within tolerance cannot be found, the point is skipped.

TIP - To stop the stakeout at any point, tap the **Esc** softkey. The stakeout stops and the software displays a message asking if you want to abandon the measurement. Tap **Yes** to stop the stakeout and display the **Results** screen. If you wish to continue, tap **No** to resume the stakeout.

5. When auto stake center line is complete, the **Results** screen shows the number of points staked and the number of points skipped.

If any points were skipped, tap the **Retry** softkey to retry auto staking the skipped points. Tap the **Tolerance** softkey to change the tolerance settings, if required.

To auto stake a gradeline

Automatically stake out a gradeline along all surfaces of the mine. You can start and stop auto stakeout at any point in the stakeout workflow.

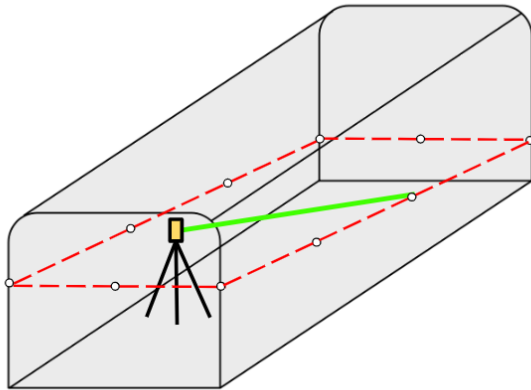

1. To define the gradeline and auto stake sequence:
 - a. Start by doing one of the following:
 - In the map, select the line and then tap **Auto stake / Gradeline**.
 - Tap **☰** and select **Auto stake / Gradeline** and select the **Start point** and the **End point**.
When selecting points, select them from the map or tap **▶** for other selection methods.
 - b. Define an **Interval** for staking the line.
 - c. Select the **Start surface** from which to begin the auto stake routine and then define the **Sequence** in which the auto stake routine will stake each surface.
The **Start surface** options are: left side, front face, right side, rear face. By default the stakeout will begin at the left side, and continue in the following order: front face, right side, rear face.
To reverse the sequence, tap the **Reverse** softkey. This setting is remembered if you repeat the stakeout of the line.
 - d. If required, define a **Vertical offset**, which can be applied above or below the gradeline.
The offset is used to adjust the design positions.
 - e. By default, the stakeout will begin at the left side, and continue in this order: front face, right side, rear face. To reverse the stakeout order, tap the **Reverse** softkey. This setting is remembered if you repeat the stakeout of the line.

TIP – In both the map and camera views, the defined centerline appears as a black dashed line. A yellow arrow highlights the active surface and indicates the staking direction.

2. Tap **Next**.
3. Tap the **Options** softkey to enter values for the **Point details**, **Position tolerance**, and **Settings** or accept the default values. See [Auto stake settings, page 22](#). Tap **Next**.

NOTE – Position tolerance values refer to the tolerance when searching for the next position on the mine surface. Position tolerance in this context does not refer to the precision or accuracy of the measured point.

Before the auto stake routine can start, you must measure the existing mine surfaces as well as the defined start point. This allows the software to accurately project the design gradeline onto each mine face and determine the intersection points for marking. Measuring to the start point helps with efficiency and avoids rework.

4. Measure the mine faces and the auto stake start position:

NOTE – Measuring close to the center of the mine surface will provide the best results.

- a. Aim to the front face and tap **Measure**.
- b. Aim to the left side and tap **Measure**.
- c. Aim to the right side and tap **Measure**.
- d. Aim to the rear face and tap **Measure**.

To remove the rear face from the measurement workflow, tap the **Skip** softkey when prompted to measure the rear face.

- e. Aim to the start point and tap **Measure**. To start the auto-stakeout from the start point of the defined gradeline, tap **Skip**.

The autostake routine automatically begins after you have measured to the mine surfaces and the autostake start position.

- If you measured an auto stake start point, the auto stakeout begins at that point and proceeds in the sequence you defined in step 1.
- If you skipped measuring the start position, the auto stakeout proceeds from the start of the defined gradeline and proceeds in the default stakeout order.

During auto stakeout:

- When a position is found within tolerance, the **Mark point** event sounds and:
 - If the instrument has a tracklight, the laser pointer **and** the tracklight **flash** for the period defined in the **Mark delay** field.

- If the instrument is a Trimble SX12 scanning total station, the instrument changes to **STD** mode and the laser pointer **stops flashing** and moves to position itself at the EDM location. The laser pointer **changes to solid** while the Target Illumination light (TIL) flashes for the period defined in the **Mark delay** field. When the point is stored the instrument automatically returns to **TRK** mode and the laser pointer resumes flashing.
- If a change in grade is detected, the **Grade Change** event sounds and is displayed in the status bar. The controller will also vibrate to indicate a grade change.
At the end of the **Mark delay** period the instrument auto stakes the next point. Tap **Pause** to temporarily halt the auto stake process. Use the **Prev** and **Next** softkeys to skip to the previous or next point.
- During the iteration process, the stakeout deltas are displayed, indicating the direction the instrument EDM needs to go to reach the target. A value shown in red indicates the deltas are out of tolerance. Tap **Pause** to temporarily halt the iteration. The software switches the instrument to tracking mode, allowing you to use the arrow keys on the controller or the video screen to move the instrument EDM closer to the target. Once the delta values are shown in black, tap **Store** to store the record, restart the auto stakeout sequence, and move to the mark point step.
- If a point within tolerance cannot be found, the point is skipped.

TIP – To stop the stakeout at any point, tap the **Esc** softkey. The stakeout stops and the software displays a message asking if you want to abandon the measurement. Tap **Yes** to stop the stakeout and display the **Results** screen. If you wish to continue, tap **No** to resume the stakeout.

5. When auto stake gradeline is complete, the **Results** screen shows the number of points staked and the number of points skipped.

If any points were skipped, tap the **Retry** softkey to retry auto staking the skipped points. Tap the **Tolerance** softkey to change the tolerance settings, if required.

To auto stake laser lines

Automatically stake out laser line points along the mine face using a design file or by calculating new laser line locations along the grade line.

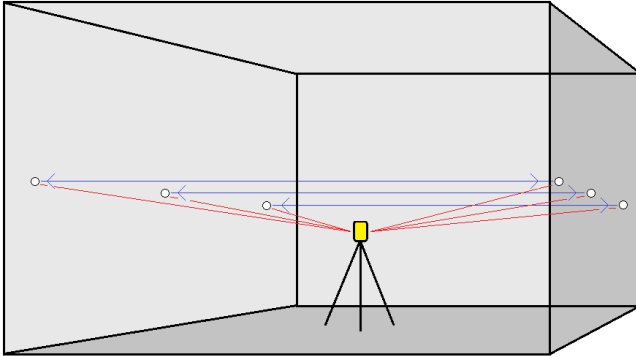

1. To create the laser lines:

- In the map, select the line(s) and then tap **Auto stake / Laser lines**.

When you select laser lines from the map by dragging a box around them, the laser line definitions are now listed in the order they are defined in the file. When you select them by tapping them individually in the map, the laser line definitions are still shown in the order selected in which you selected them in the map.

- Tap **☰** and select **Auto stake / Laser lines** and select the points:
 - a. Set the **Selection method** to either **Prefix** or **Suffix** so it matches the naming convention of the points in your job.
 - b. Enter the **Left points prefix/suffix** and the **Right points prefix/suffix**. Tap **Next**.

All matching pairs in the job with the correct prefix/suffix are listed.

Matched pairs of points must be defined using their point names. A point must have a prefix or suffix to identify it as the left or the right hand end of the line. The remainder of the point name must be identical for a match pair to be found. For example, if the Left points prefix is L and the Right points prefix is R, then the following points would be identified as matched pairs: L1-R1, L15-R15, L101-R101, etc.

- c. If required, select and delete any points that do not require staking.
- d. Tap **Next**.

To reverse the direction of the line, tap **Swap**. Tap **Next**.

2. Enter values for the **Point details** and **Settings**, or accept the default values.

NOTE – By default the Mines software stakes all the points on the left, starting with the first line and finishing on the last. It then stakes all the points on the right side, starting with the last line and finishing on the first. To change to an alternating stakeout (or "zig zag" order) select **Alternating stakeout order**.

3. Tap **Next**.

The software will automatically start the auto stake laserline routine.

TIP – If the instrument fails to point in the correct direction, during the **Start delay** period, you can manually point the instrument in the correct direction.

The instrument turns to the design point, measures a position and then checks this position against the defined tolerances. If it is outside the tolerances it turns to a new position and repeats the process until a position within tolerance is found, or the maximum number of iterations is reached.

The software will use the previous position to reduce the number of iterations required to find the next position. However if a position is not found within tolerance the software will use the design position of the previous position to reduce the number of iterations required to find the next position.

- When a position is found within tolerance, the **Mark point** event sounds and:
 - If the instrument has a tracklight, the laser pointer **and** the tracklight **flash** for the period defined in the **Mark delay** field.
 - If the instrument is a Trimble SX12 scanning total station, the instrument changes to **STD** mode and the laser pointer **stops flashing** and moves to position itself at the EDM location. The laser pointer **changes to solid** while the Target Illumination light (TIL) flashes for the period defined in the **Mark delay** field. When the point is stored the instrument automatically returns to **TRK** mode and the laser pointer resumes flashing.

At the end of the **Mark delay** period the instrument auto stakes the next point. Tap **Pause** to temporarily halt the auto stake process. Use the **Prev** and **Next** softkeys to skip to the previous or next point.

- While the software is iterating to find a point within tolerance of the target, tap **Pause** to temporarily halt the iteration process. The software switches the instrument to tracking mode and shows the stakeout deltas, which indicate the direction the instrument EDM needs to go to reach the target. A value shown in red indicates the deltas are out of tolerance. Use the arrow keys on the controller or the arrow keys on the video screen to move the instrument EDM closer to the target. Once the delta values are shown in black tap **Store** to store the record, restart the auto stakeout sequence, and move to the mark point step.
- If a point within tolerance cannot be found, the point is skipped.

- When the process has finished, the **Results** screen shows the number of points staked and the number of points skipped.

To auto stake laser lines from a centerline

Automatically stake out laser lines offset from a centerline. The laser lines are defined at regular intervals at right angles relative to the centerline.

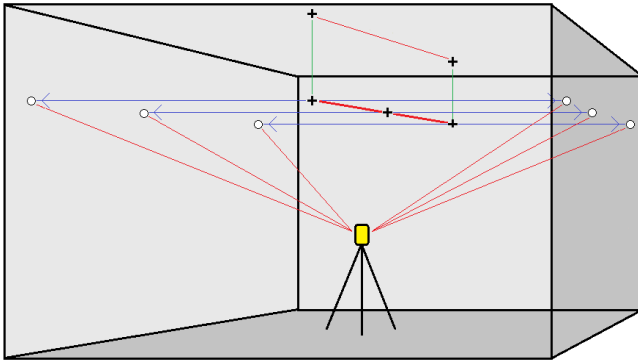

- To create the centerline:
 - In the map, select the line(s) and then tap **Auto stake / Laser lines offset from CL**.
 - Tap **☰** and select **Auto stake / Laser lines offset from CL** and select the start and end points.

When selecting points, select them from the map or tap **▶** for other selection methods.

To reverse the direction of the line, tap **Swap**.

- Then:
 - Define an **Interval** for staking the line.
 - If required, define offsets. The centerline can be offset by a:
 - Vertical offset** – applied above or below the centerline
 - Station offset** – applied backward or forward along the centerline
 These offsets are used to calculate the design positions.
 - To extend the centerline, enter the extension distance in the **Extend beyond end point** field. To shorten the centerline, enter a negative value in this field.
 - Tap **Next**.
- Review the defined laser lines. Select and delete any lines that do not require staking. Tap **Next**.
- Enter values for the **Point details** and **Settings**, or accept the default values. Tap **Next**.
- To aid in the auto stakeout of the laser lines you are prompted to aim and measure a position on the right side of the mine. Repeat when prompted for the left side.
- Tap **Next**.

The Mines software stakes all the points on the left, starting with the first line and finishing on the last. It then stakes all the points on the right side, starting with the last line and finishing on the first..

TIP – If the instrument fails to point in the correct direction, during the **Start delay** period, you can manually point the instrument in the correct direction.

The software will use the previous position to reduce the number of iterations required to find the next position. However if a position is not found within tolerance the software will use the design position of the previous position to reduce the number of iterations required to find the next position.

- When a position is found within tolerance, the **Mark point** event sounds and:
 - If the instrument has a tracklight, the laser pointer **and** the tracklight **flash** for the period defined in the **Mark delay** field.
 - If the instrument is a Trimble SX12 scanning total station, the instrument changes to **STD** mode and the laser pointer **stops flashing** and moves to position itself at the EDM location. The laser pointer **changes to solid** while the Target Illumination light (TIL) flashes for the period defined in the **Mark delay** field. When the point is stored the instrument automatically returns to **TRK** mode and the laser pointer resumes flashing.

At the end of the **Mark delay** period the instrument auto stakes the next point. Tap **Pause** to temporarily halt the auto stake process. Use the **Prev** and **Next** softkeys to skip to the previous or next point.

- While the software is iterating to find a point within tolerance of the target, tap **Pause** to temporarily halt the iteration process. The software switches the instrument to tracking mode and shows the stakeout deltas, which indicate the direction the instrument EDM needs to go to reach the target. A value shown in red indicates the deltas are out of tolerance. Use the arrow keys on the controller or the arrow keys on the video screen to move the instrument EDM closer to the target. Once the delta values are shown in black tap **Store** to store the record, restart the auto stakeout sequence, and move to the mark point step.
 - If a point within tolerance cannot be found, the point is skipped.
7. When the process has finished, the **Results** screen shows the number of points staked and the number of points skipped.

To auto stake blast holes

Automatically stake out blast hole points in the mine using a design file or by selecting them from the map or from the menu.

A blast hole point is the intersection point between the mine face and a line defined by two points – the collar point and the toe point.

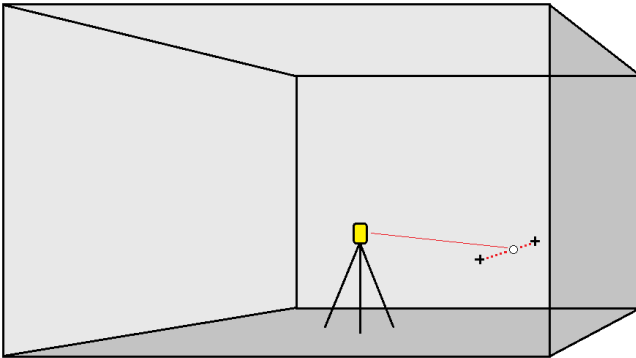

1. To select the blast holes:

- In the map, select the line(s) that define the blast holes and then tap **Auto stake / Blast holes**.

When you select blast holes by:

- dragging a box around them in the map, the blast hole definitions are listed in the order they are defined in the file.
- tapping them individually in the map, the blast hole definitions are shown in the order in which you selected them in the map.
- Tap **☰** and select **Auto stake / Blast holes** and select the points:
 - a. Set the **Selection method** to either **Prefix** or **Suffix** so it matches the naming convention of the points in your job.
 - b. Enter the **Collar points prefix/suffix** and the **Toe points prefix/suffix**. Tap **Next**.

All matching pairs in the job with the correct prefix/suffix are listed.

Matched pairs of points must be defined using their point names. A point must have a prefix or suffix to identify it as the blast hole collar or toe. The remainder of the point name must be identical for a match pair to be found. For example, if the collar points suffix is C and the toe points suffix is T, then the following points would be identified as matched pairs: 1C-1T, 15C-15T, A1C-A1T, etc.

2. Review the selected blast hole points:

- If required, select and remove any points from the list that do not require staking. Press **Ctrl** to select more than one point at a time and then tap **Remove**.

To remove several points at once you can also select a point in the list and then tap the **Remove** ↓ softkey to remove all points in the list below the selected point, or tap the **Remove** ↑ softkey to remove all points in the list above the selected point.

- To sort the points alphabetically, tap the **Collar** column header.
- To manually reorder the points, tap them in the list and drag them up or down.
- To reverse the direction of the line, select it from the list and then tap **Swap**.

Changes you make to the selected points, point order, or line direction from the list are reflected in the map.

3. Tap **Next**.
4. Enter values for the **Point details** and **Settings**, or accept the default values.
5. Tap **Next**.

TIP – If the instrument fails to point in the correct direction, during the **Start delay** period, you can manually point the instrument in the correct direction.

The instrument turns to the design point, measures a position and then checks this position against the defined tolerances. If it is outside the tolerances it turns to a new position and repeats the process until a position within tolerance is found, or the maximum number of iterations is reached.

The software will use the previous position to reduce the number of iterations required to find the next position. However if a position is not found within tolerance the software will use the design position of the previous position to reduce the number of iterations required to find the next position.

- When a position is found within tolerance, the **Mark point** event sounds and:
 - If the instrument has a tracklight, the laser pointer **and** the tracklight **flash** for the period defined in the **Mark delay** field.
 - If the instrument is a Trimble SX12 scanning total station, the instrument changes to **STD** mode and the laser pointer **stops flashing** and moves to position itself at the EDM location. The laser pointer **changes to solid** while the Target Illumination light (TIL) flashes for the period defined in the **Mark delay** field. When the point is stored the instrument automatically returns to **TRK** mode and the laser pointer resumes flashing.

At the end of the **Mark delay** period the instrument auto stakes the next point. Tap **Pause** to temporarily halt the auto stake process. Use the **Prev** and **Next** softkeys to skip to the previous or next point.

- While the software is iterating to find a point within tolerance of the target, tap **Pause** to temporarily halt the iteration process. The software switches the instrument to tracking mode and shows the stakeout deltas, which indicate the direction the instrument EDM needs to go to reach the target. A value shown in red indicates the

deltas are out of tolerance. Use the arrow keys on the controller or the arrow keys on the video screen to move the instrument EDM closer to the target. Once the delta values are shown in black tap **Store** to store the record, restart the auto stakeout sequence, and move to the mark point step.

- If a point within tolerance cannot be found, the point is skipped.
6. When the process has finished, the **Results** screen shows the number of points staked and the number of points skipped.

To auto stake pivot points

Automatically stake out pivot points using a design file or by calculating new pivot point locations in the field.

The software projects the pivot point onto the mine back (ceiling) so that you can mark it before moving to the next pivot point.

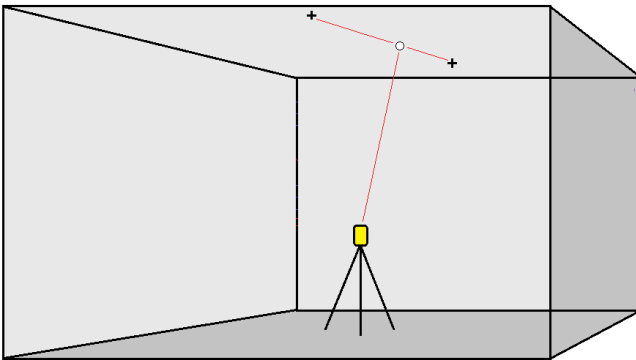

1. To define the pivot points:
 - In the map, select the pivot points and then tap **Auto stake / Pivot points**.

TIP – If the job does not already contain pivot points, you can select other points in the map and use them to define pivot points. See [To define pivot points from other map points, page 19](#).

 - Tap **☰** and select **Auto stake / Pivot points** and select the points:
 - a. Set the **Selection method** to either **Prefix** or **Suffix** so it matches the naming convention of the points in your job.
 - b. Enter the **Pivot points prefix/suffix**. Tap **Next**.
All points in the job with the correct prefix/suffix are listed.
 - c. If required, select and delete any points that do not require staking.
 - d. Tap **Next**.

To reverse the direction of the line, tap **Swap**.

2. Enter values for the **Point details** and **Settings**, or accept the default values. Tap **Next**.

3. When prompted, aim the instrument at the mine back and then tap **Measure**. This ensures that the auto staked points will be located on the back.

The instrument turns to the design point, measures a position and then checks this position against the defined tolerances. If it is outside the tolerances it turns to a new position and repeats the process until a position within tolerance is found, or the maximum number of iterations is reached.

The software will use the previous position to reduce the number of iterations required to find the next position. However if a position is not found within tolerance the software will use the design position of the previous position to reduce the number of iterations required to find the next position.

- When a position is found within tolerance, the **Mark point** event sounds and:
 - If the instrument has a tracklight, the laser pointer **and** the tracklight **flash** for the period defined in the **Mark delay** field.
 - If the instrument is a Trimble SX12 scanning total station, the instrument changes to **STD** mode and the laser pointer **stops flashing** and moves to position itself at the EDM location. The laser pointer **changes to solid** while the Target Illumination light (TIL) flashes for the period defined in the **Mark delay** field. When the point is stored the instrument automatically returns to **TRK** mode and the laser pointer resumes flashing.

At the end of the **Mark delay** period the instrument auto stakes the next point. Tap **Pause** to temporarily halt the auto stake process. Use the **Prev** and **Next** softkeys to skip to the previous or next point.

- While the software is iterating to find a point within tolerance of the target, tap **Pause** to temporarily halt the iteration process. The software switches the instrument to tracking mode and shows the stakeout deltas, which indicate the direction the instrument EDM needs to go to reach the target. A value shown in red indicates the deltas are out of tolerance. Use the arrow keys on the controller or the arrow keys on the video screen to move the instrument EDM closer to the target. Once the delta values are shown in black tap **Store** to store the record, restart the auto stakeout sequence, and move to the next mark step.
 - If a point within tolerance cannot be found, the point is skipped.
4. When the process has finished, the **Results** screen shows the number of points staked and the number of points skipped.

To define pivot points from other map points

Defining pivot points from points in the map is useful if the drive deviates from design and a new centerline has to be defined, requiring the pivot points defined by the intersection of the centerline with the laser lines to be recomputed.

To define pivot points from map points:

1. Select the two points that define the centerline and a laser line and then select the **Compute intersection** option from the tap and hold menu to compute a point at the intersection with the option to derive the elevation from the centerline.
2. Once the computed point is stored select the next laser line from the map and repeat the process.
3. When all pivot points have been computed you can select them ready for auto staking.

To project a line

Automatically stake out projected line points at an offset from your laser line to create a new reference line between the laser line and the mine face.

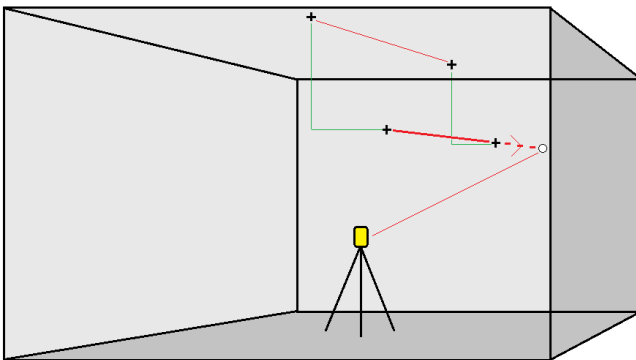

1. To create the line:
 - In the map, select the line and then tap **Auto stake / Project line**.
 - Tap **☰** and select **Auto stake / Project line** and select the start and end points. When selecting points, select them from the map or tap **▶** for other selection methods.

To reverse the direction of the line, tap **Swap**.

2. If required, define offsets. The projected line can be offset by a:
 - **Horizontal offset** – applied left or right of the line
 - **Vertical offset** – applied up or down from the line
3. Tap **Next**.
4. Enter values for the **Point details**, **Position tolerance**, and **Settings** or accept the default values. See [Auto stake settings, page 22](#). **NOTE** – Position tolerance values refer to the tolerance

when searching for the next position on the mine surface. Position tolerance in this context does not refer to the precision or accuracy of the measured point. Tap **Next**.

5. Tap **Next**.

TIP – If the instrument fails to point in the correct direction, during the **Start delay** period, you can manually point the instrument in the correct direction.

The instrument turns to the design point, measures a position and then checks this position against the defined tolerances. If it is outside the tolerances it turns to a new position and repeats the process until a position within tolerance is found, or the maximum number of iterations is reached.

The software will use the previous position to reduce the number of iterations required to find the next position. However if a position is not found within tolerance the software will use the design position of the previous position to reduce the number of iterations required to find the next position.

- When a position is found within tolerance, the **Mark point** event sounds and:
 - If the instrument has a tracklight, the laser pointer **and** the tracklight **flash** for the period defined in the **Mark delay** field.
 - If the instrument is a Trimble SX12 scanning total station, the instrument changes to **STD** mode and the laser pointer **stops flashing** and moves to position itself at the EDM location. The laser pointer **changes to solid** while the Target Illumination light (TIL) flashes for the period defined in the **Mark delay** field. When the point is stored the instrument automatically returns to **TRK** mode and the laser pointer resumes flashing.

At the end of the **Mark delay** period the instrument auto stakes the next point. Tap **Pause** to temporarily halt the auto stake process. Use the **Prev** and **Next** softkeys to skip to the previous or next point.

- While the software is iterating to find a point within tolerance of the target, tap **Pause** to temporarily halt the iteration process. The software switches the instrument to tracking mode and shows the stakeout deltas, which indicate the direction the instrument EDM needs to go to reach the target. A value shown in red indicates the deltas are out of tolerance. Use the arrow keys on the controller or the arrow keys on the video screen to move the instrument EDM closer to the target. Once the delta values are shown in black tap **Store** to store the record, restart the auto stakeout sequence, and move to the mark point step.
 - If a point within tolerance cannot be found, the point is skipped.
6. When the process has finished, the **Results** screen shows the number of points staked and the number of points skipped.

To auto stake wall lasers

Automatically stake out wall lasers for enhanced precision in guiding drilling equipment.

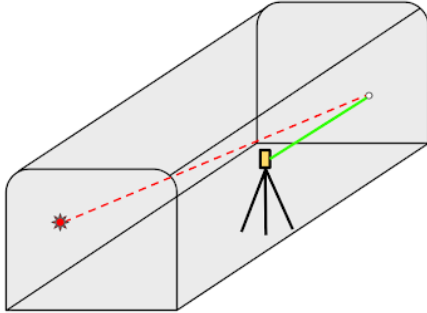

This workflow allows you to position wall lasers two ways:

- A **manual solution** is calculated by aiming the instrument laser at a specific mount point and a desired location on the rock face.
- An **optimised solution** finds the best possible wall laser line based on the initial mount point, centerline and wall design, wall clearance and grade.

Both of these methods use your manual input to provide a precise reference for guiding drilling at the working face.

1. To calculate where to position the wall laser:
 - a. Start by doing one of the following:
 - In the map, select the mine centerline and then tap **Auto stakeout / Wall laser**.
 - Tap **☰** and select **Auto stakeout / Wall laser**.
 - b. Confirm or select the mine centerline from the design in the map and tap **Next**.
 - c. Select the wall design linework from the design in the map and tap **Next**.
 - d. Aim the instrument laser at the desired mount point, then choose how the laser grade will be calculated. You can either select **Height Above Centerline** to use the automatically calculated value or select **Grade** to manually enter a specific value. Tap the arrow next to the grade input field and select **Down** to indicate a decline and **Up** to indicate an incline. Tap **Next**.
 - e. Aim the laser at the rock face where you want the laser line to go.

TIP – At any point in the workflow you can move the instrument or go back to change the solution and then the software will recalculate.

The software calculates a **manual solution**, based on where the surveyor pointed the instrument at the rock face. The manual solution is shown as a **dashed** green line on the map and the results are shown in the **Laser solution** box.

2. To calculate an **optimized solution**:
 - a. If required, tap **Options** to adjust the **Wall clearance** value in the **Best solution search parameters** group box. Tap **Accept** to return to the wall laser workflow.
 - b. Tap the **Snap to best** softkey to calculate the optimized solution, based on the selected mount point and the **Wall clearance** value.

The software calculates the optimized solution, based on the mount point, centerline and wall design, and grade. The optimized solution is shown as a **solid** green line on the map and the results are shown in the **Laser solution (Best)** box.

3. When you are ready to install the wall laser, use the **Turn to mount** and **Turn to rock face** softkeys for assistance during installation.
4. Once the wall laser is installed:
 - a. Tap **Next**.
 - b. Enter the name and code of the final laser mount point and tap **Measure** to store.
 - c. Enter the name and code of the final rock face point and tap **Measure** to store.
 - d. Enter the name and code of the projected end point of the wall laser line and tap **Next**.
The results of the laser solution, mount point, rock face point and end point are displayed.
 - e. Tap **Store**.

Auto stake settings

The **Settings** form appears when you tap **Next** in the **Auto stake** form.

Point details

Specify the **Start point** and **Point code**.

Position tolerance

Specify the tolerances for a centerline or grade line.

NOTE – Position tolerance values refer to the search functions on the mine surface, not the accuracy of the position.

The **Station** tolerance value applies forward and back along the line.

The **Offset** tolerance is defined left and right of the line.

The **Grade** tolerance is defined up and down from the line and perpendicular to the line.

Settings

The fields in the **Settings** group control the behavior of the software during auto stakeout.

EDM timeout

To improve performance, reduce the length of the **EDM timeout**. If the instrument struggles to get a measurement due to, for example, reflective or dark surfaces, increase the **EDM timeout**.

Mark delay

The **Mark delay** is the length of time, in seconds, that the laser pointer flashes once the position is found.

When a position is found within tolerance, the **Mark point** event sounds and:

- If the instrument has a tracklight, the laser pointer **and** the tracklight flash for the period defined in the **Mark delay** field.
- If the instrument is a Trimble SX12 scanning total station, the laser pointer **changes to solid** and the Target Illumination light (TIL) flashes for the period defined in the **Mark delay** field.

If a point within tolerance cannot be found, the point is skipped.

Start delay

The **Start delay** gives you time to walk to the location of the first point to be marked. If the number of **Iterations** is exceeded, or the EDM times out, the point is skipped.

Measure to define laser line elevation

Select the **Measure to define laser line elevation** check box when:

- You want to override the elevation of the points used to define the laser line.
- The points defining the laser line have no elevation or have an arbitrary elevation of 0. This can be the case when the laser lines are defined from lines in a DXF file.

If you select the **Measure to define laser line elevation** check box, you are prompted to take a measurement before the autostake process begins. The measured elevation is then used to define the elevation for the line.

Legal notices

Trimble Inc.

www.trimble.com/en/legal

Copyright and trademarks

© 2026, Trimble Inc. All rights reserved.

Trimble, the Globe and Triangle logo, Autolock, CenterPoint, FOCUS, Geodimeter, GPS Pathfinder, GPS Total Station, OmniSTAR, ProPoint, RealWorks, Spectra, Terramodel, Tracklight, Trimble Connect, Trimble RTX, and xFill are trademarks of Trimble Inc. registered in the United States and in other countries.

Access, Catalyst, FastStatic, FineLock, GX, IonoGuard, ProPoint, RoadLink, TerraFlex, TIP, Trimble Inertial Platform, Trimble Geomatics Office, Trimble Link, Trimble Survey Controller, Trimble Total Control, TRIMMARK, VISION, VRS, VRS Now, VX, and Zephyr are trademarks of Trimble Inc.

Microsoft, Excel, Internet Explorer, and Windows are either registered trademarks or trademarks of Microsoft Corporation in the United States and/or other countries.

Google and Android are trademarks of Google LLC.

The Bluetooth word mark and logos are owned by the Bluetooth SIG, Inc. and any use of such marks by Trimble Inc. is under license.

Wi-Fi and Wi-Fi HaLow are either registered trademarks or trademarks of the Wi-Fi Alliance.

All other trademarks are the property of their respective owners.

This software is based in part on the work of the Independent JPEG Group, derived from the RSA Data Security, Inc, MD5 Message-Digest Algorithm.

This product includes software developed by the OpenSSL Project for use in the OpenSSL Toolkit (www.openssl.org/).

Trimble Access includes a number of open source libraries.

For more information, see [Open source libraries used by Trimble Access](#).

The Trimble Coordinate System Database provided with the Trimble Access software uses data from a number of third parties. For more information, see [Trimble Coordinate System Database Open Source Attribution](#).

The Trimble Maps service provided with the Trimble Access software uses data from a number of third parties. For more information, see [Trimble Maps Copyrights](#).

For Trimble General Product Terms, go to www.trimble.com/en/legal.