

# Trimble X9

## 3D LASER SCANNER

### EUROPE

Hereby, Trimble® declares that the X9 3D Laser Scanner is in compliance with the following directives:

- RED 2014/53/EU
- RoHS Directive 2011/65/EU including its subsequent amendment: Directive 2015/863/EU



### Information about included radio modules

WLAN radio module:

- Manufacturer: Trimble
- Type designation: V0009F
- Frequency band: 2412 to 2472 MHz; 5150 to 5350 MHz, 5470 to 5730 MHz, 5735 to 5835 MHz
- Max conducted RF output power (2.4 GHz WLAN, single chain): 18 dBm
- Max conducted RF output power (5 GHz WLAN, single chain): 15 dBm

### Notice to our European customers (WEEE)

For product recycling instructions and more information, please go to [trimble.com/Corporate/Environmental\\_Compliance.aspx](https://www.trimble.com/Corporate/Environmental_Compliance.aspx).



## UNITED KINGDOM

Trimble declares that the X9 3D Laser Scanner is in compliance with the following directives:

- Radio Equipment Regulations 2017
- The Restriction of the Use of Certain Hazardous Substances in Electrical and Electronic Equipment Regulations 2012



## USA

This device complies with part 15 of the FCC rules. Operation is subject to the following two conditions:

1. This device may not cause harmful interference.
2. This device must accept any interference received, including interference that may cause undesired operation.

**NOTE** – This equipment has been tested and found to comply with the limits for a Class A digital device, pursuant to part 15 of the FCC Rules. These limits are designed to provide reasonable protection against harmful interference when the equipment is operated in a commercial environment. This equipment generates, uses, and can radiate radio frequency energy and, if not installed and used in accordance with the instruction manual, may cause harmful interference to radio communications. Operation of this equipment in a residential area is likely to cause harmful interference in which case the user will be required to correct the interference at their own expense.

**CAUTION** – Changes or modifications not expressly approved by the manufacturer could void the user's authority to operate the equipment.

## CANADA

This Class A digital apparatus complies with Canadian ICES-003.

This device complies with Industry Canada license-exempt RSS standard(s). Operation is subject to the following two conditions:

1. This device may not cause interference, and
2. This device must accept any interference, including interference that may cause undesired operation of the device.

Cet appareil numérique de la classe A est conforme à la norme NMB.003 du Canada.

Le présent appareil est conforme aux CNR d'Industrie Canada applicables aux appareils radio exempts de licence. L'exploitation est autorisée aux deux conditions suivantes:

1. l'appareil ne doit pas produire de brouillage, et
2. l'utilisateur de l'appareil doit accepter tout brouillage radioélectrique subi, même si le brouillage est susceptible d'en compromettre le fonctionnement.

## JAPAN

The 5.2 and 5.3 GHz band is restricted to indoor use due to the Japanese Radio Law. The radio module and the host device is labeled with a specific label in relation to the Japanese Radio Law.

日本の電波法により、5.2および5.3 GHz帯域は屋内での使用に制限されています。無線モジュールおよびホストデバイスには、日本の電波法に関連する特定のラベルが付けられています。

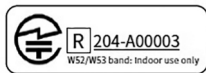

## BATTERY SAFETY INFORMATION

**WARNING** – Do not damage the rechargeable Lithium-ion battery. A damaged battery can cause an explosion or fire, and can result in personal injury and/or property damage. To prevent injury or damage:

- Do not use or charge the battery if it appears to be damaged. Signs of damage include, but are not limited to, discoloration, warping, and leaking battery fluid.
- Do not expose the battery to fire, high temperature, or direct sunlight.
- Do not immerse the battery in water.
- Do not use or store the battery inside a vehicle during hot weather.
- Do not drop or puncture the battery.
- Do not open the battery or short-circuit its contacts.

**WARNING** – Avoid contact with the rechargeable Lithium-ion battery if it appears to be leaking. Battery fluid is corrosive, and contact with it can result in personal injury and/or property damage. To prevent injury or damage:

- If the battery leaks, avoid contact with the battery fluid.
- If battery fluid gets into your eyes, immediately rinse your eyes with clean water and seek medical attention. Do not rub your eyes!
- If battery fluid gets onto your skin or clothing, immediately use clean water to wash off the battery fluid. If skin irritation or pain persists, seek medical attention.

**WARNING** – Charge and use the rechargeable Lithium-ion battery only in strict accordance with the instructions. Charging or using the battery in unauthorized equipment can cause an explosion or fire, and can result in personal injury and/or equipment damage. To prevent injury or damage:

- Do not charge or use the battery if it appears to be damaged or leaking.
- Charge the Lithium-ion battery only in a Trimble product that is specified to charge it.
- Be sure to follow all instructions that are provided with the battery charger.

- Discontinue charging a battery that gives off extreme heat or a burning odor.
- Use the battery only in Trimble equipment that is specified to use it.
- Use the battery only for its intended use and according to the instructions in the product documentation.
- Cover battery terminals with proper insulating tape before disposal to avoid heat generation by an inadvertent short-circuit.

## LASER SAFETY INFORMATION

Before using the instrument, make sure that you understand this document, as well as all equipment, job site safety requirements and regulations.

This equipment has been tested and found to comply with IEC 60825-1:2014 and IEC 60825-1:2007, 21 CFR 1040.10, and 1040.11.

**WARNING** – Viewing the laser output with telescopic optical instruments (for example, telescopes and binoculars) may pose an eye hazard and thus the user should not direct the beam into an area where such instruments are likely to be used.

**WARNING** – Use of controls or adjustments or performance of procedures other than those specified in the user documentation may result in hazardous LED or laser radiation exposure. As with any bright light source, such as the sun, electric welding arcs or arc lamps, common sense applies. DO NOT look into the laser aperture when the laser is on. For further information regarding safe use of lasers, refer to IEC 60825-1:2007 and IEC 60825-1:2014.

## Apertures

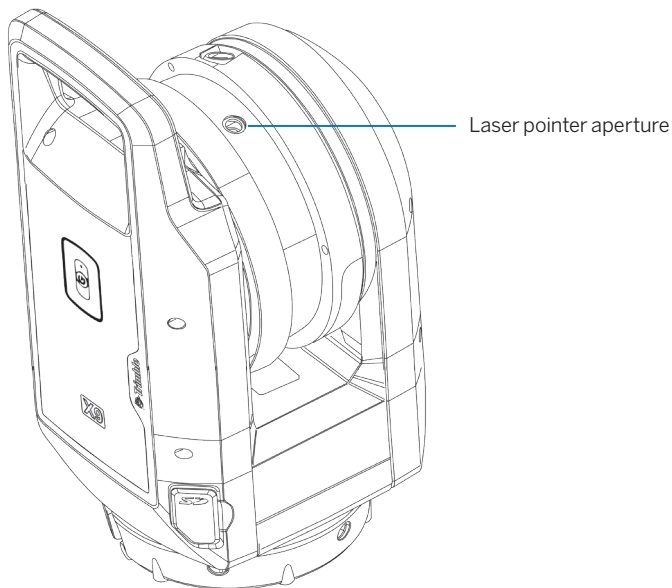

## X9 3D Laser Scanner

The instrument contains visible and invisible laser sources.

A class 2 laser with a wavelength of 620 to 650 nm for laser pointer function when enabled by the field software.

A class 1 laser with a wavelength of 1530 to 1570 nm for scanning measurements.

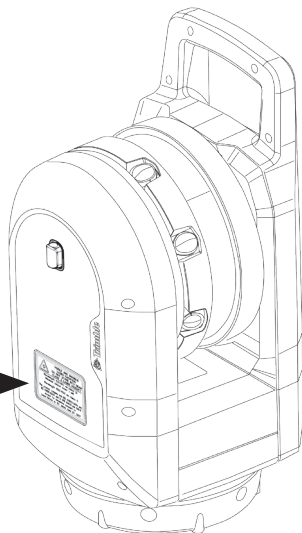

## ADDITIONAL INFORMATION

The original document is written in English. All documents in other languages are translations from the original English document. For more information and information in other languages, go to [geospatial.trimble.com/X9](https://geospatial.trimble.com/X9).

For Trimble support, go to [trimble.com/support](https://trimble.com/support).

© 2022-2024, Trimble Inc. All rights reserved. Trimble, and the Globe & Triangle logo are trademarks of Trimble, registered in the United States and in other countries. All other trademarks are the property of their respective owners.

P/N 77002054-ENG, Rev B (September 2024).



### Europe

Trimble Europe BV  
Industrieweg 187A  
5683 CC, Best  
Netherlands

### North America/ Rest of World

Trimble Inc.  
4450 Gibson Dr  
Tipp City, OH 45371  
USA

[trimble.com](https://trimble.com)